

2nd Stage TBM for PCR & LT Tires



Tread out of spool Servicer

Automatic 2nd Stage TBM

For PCR & LT tires

The Intereuropean 1st Stage & 2nd Stage TBMs provide a fully automatic solution for building high performance tyres with 2-stage technology.

The 2nd Stage TBM is equipped with active guiding systems for all the rubber components, automatic cutting and application systems, twin breaker drums on rotating turret for the cycle time optimization, bead lock type shaping drum, tread out of spool with ultra-sonic cutting, spiral nylon overlay (JLB) or nylon capply servicers, advanced control and supervision system with touch screen computer interface and advanced receipt management and diagnostics.

The machine cycle time is as low as 45 sec per tyre in fully automatic mode. The operator only checks visually machine operation and unloads the finished green tyres from the transfer ring, while the machine cycle continues.

Machine configuration and options can be adapted to any customer's specifications.



Twin Drum Rotating Belt & Tread Turret

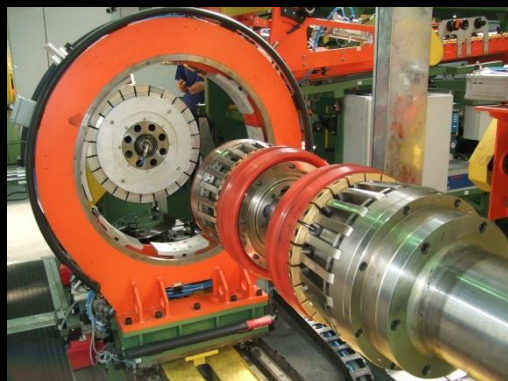

Bead Lock Shaping Drum & Transfer Ring

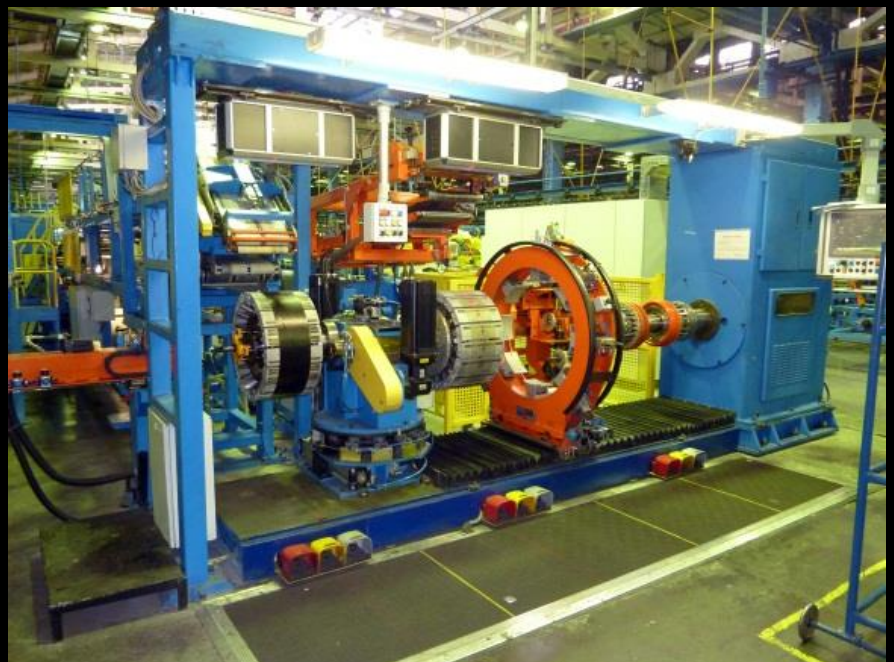

Fully Automatic 2nd Stage TBM 13" -17"

2nd Stage TBM for PCR & LT Tires

Technical Data	Values
Bead Diameter (optional)	13"-17" (15"-20")
Shaping Drum type	Bead lock
Green tyre width, max (optional)	780mm (800mm)
Breaker width (optional)	250mm (300mm)
Breaker cutting angle	18° - 30°
Tread width (optional)	300mm (350mm)
JLB/Spiral Nylon Overlay width	10-25mm
Breaker Drum dia. range	450mm - 720mm
Cycle time per carcass	Approx. 45 sec.
Operators required	1 machine operator
Required floor space	7.400mm x 10.265mm
PLC type	Allen Bradley SLC 5000
Pneumatics	FESTO
Main power supply voltage	380 V / 50 Hz / 3 phase
Control Voltage	220V / 48V / 24V
Pressure (dry air)	6 bar
Vacuum	By supplied vacuum pump

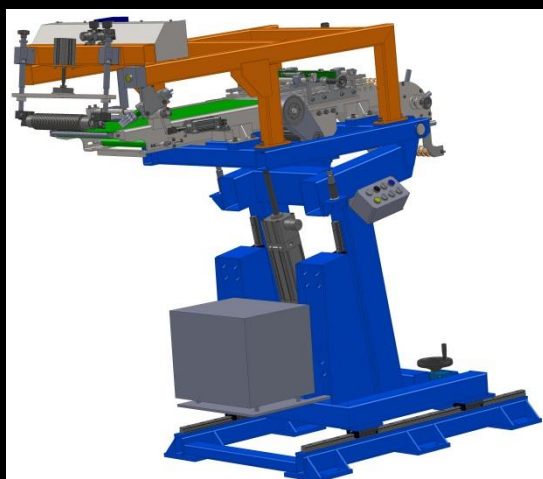
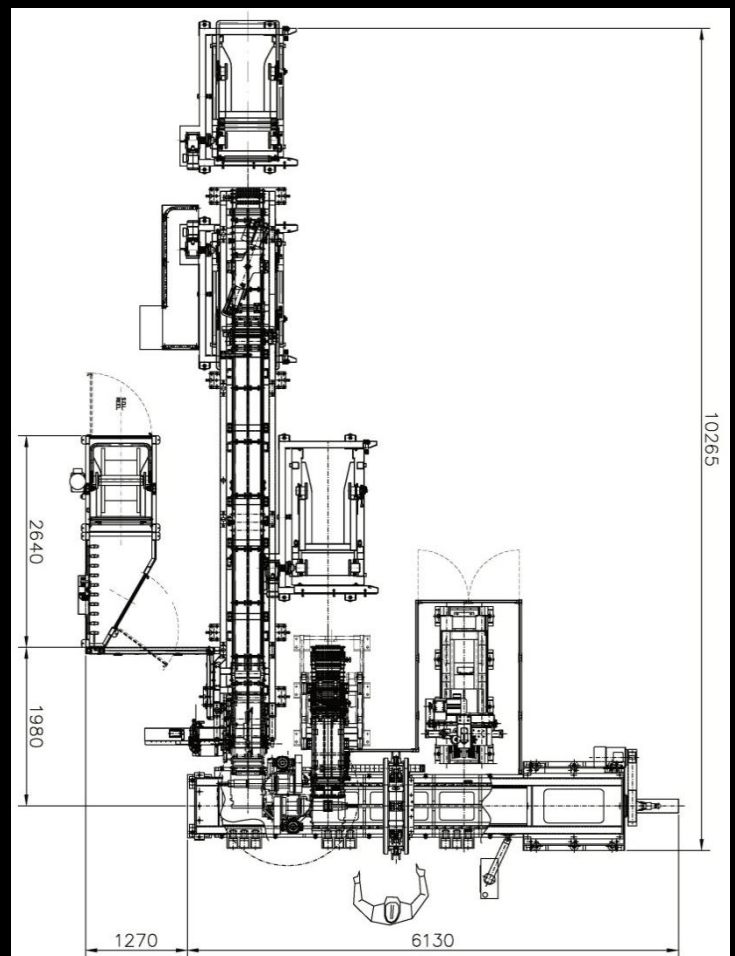
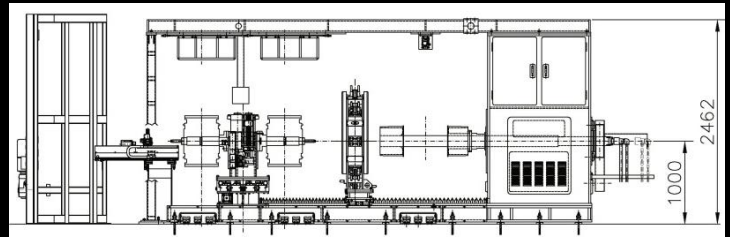

Tread out of spool Servicer

INTEREUROPEAN
Machinery & Engineering

INTEREUROPEAN S.r.l.

Via Repubblica 21, 22070 Grandate (Como) ITALY

Tel: (+39) 031 565403 Fax: (+39) 031 5472170

info@intereuropean.it <http://www.intereuropean.it>