

Ply Cutter & Splicer Lines

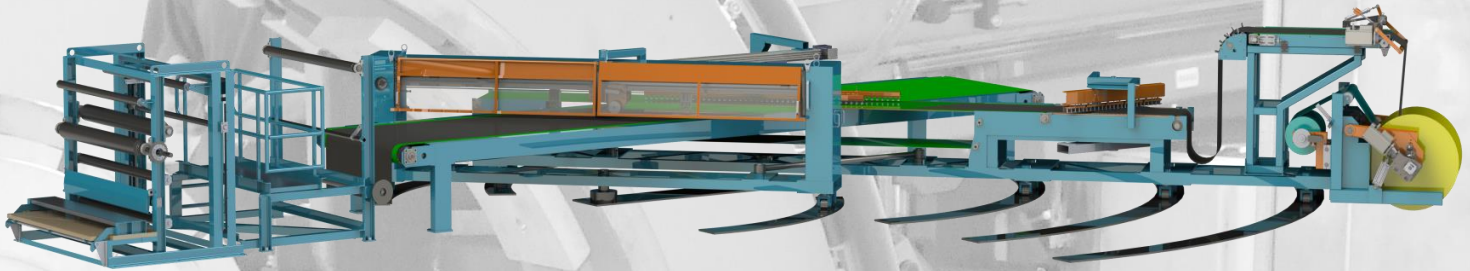

**Fully Automatic Bias Cutter & Splicer Line 40° - 90°
With optional slitter and strips winding station**

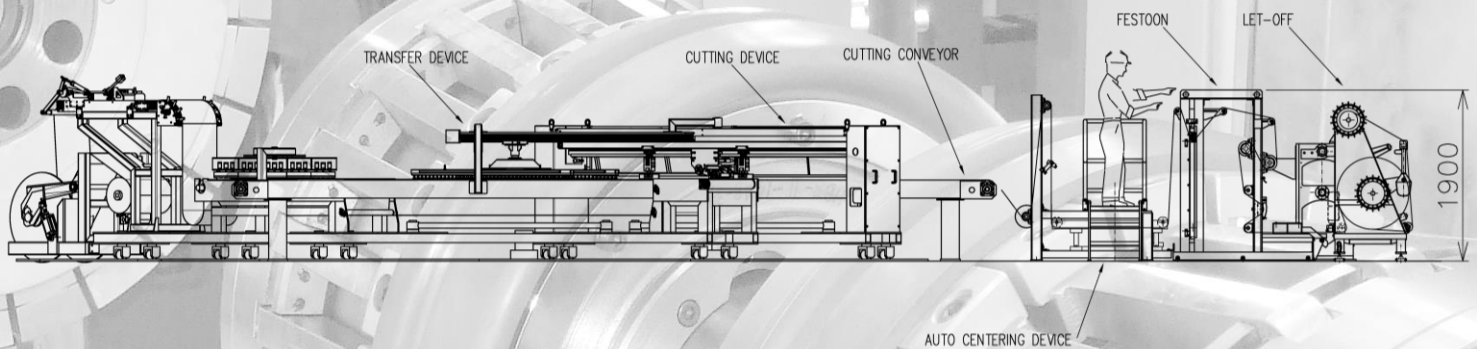

Fully Automatic textile cutting and splicing Line 40-90 degrees

Basic Configuration and available options

- Single let off for calender roll (option: Double Let-off)
- Festoon
- Automatic centering device before the cutting conveyour
- Cutting device with auto adjustable angle
- Motorized Transfer device
- Splicing conveyor
- Automatic Splicing device (overlapped or butt joint)
- Real time splice quality control system (optional)
- Strips application unit (cold or hot, top or bottom) with electronic centering (optional)
- Slitter device for multiple strips (optional)
- Single wind-up station (option: Double Wind-up)

Precision tolerances

Use of precise centering and positioning systems allow for extremely low splice tolerances of ± 0.5 mm.
Splice quality control by sheet lasers or CCD cameras assures fully automatic operation and online corrections.

Productivity

Up to 15 splices per minute for 40-90 degrees version
Up to 20 splices per minute for 90 degrees fixed angle version

INTEREUROPEAN S.r.l.

Via Mariano Tentorio 2B, 22100 Como (CO), ITALY
Phone +39 031 565403 <http://www.intereuropean.it> request@intereuropean.it

Bias Cutter & Splicer Lines

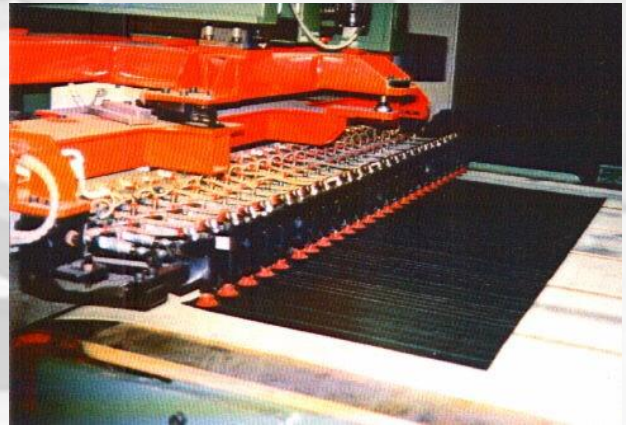

Intereuropean has a long experience in design and development of automatic and semi-automatic Bias Cutter and Splicer Lines for steel and textile cord plies.

There are various types of bias cutters with many configuration options:

1. Fully automatic cutting and splicing
2. Automatic cutting and manual splicing
3. Chafer/strips let-off and preassembling in-line
4. Various cutting angle and material width ranges

Every machine configuration is designed according to the customer's specifications.

Fully automatic Bias Cutters and Splicers for PCR tires are available in overlapped splice and butt joint configurations.

Line speeds of up to 20 splices per minute can be achieved in fully automatic mode.

**Fully Automatic
Bias Cutter Line 90°**



INTEREUROPEAN S.r.l.

Via Mariano Tentorio 2B, 22100 Como (CO), ITALY

Phone +39 031 565403 <http://www.intereuropean.it> request@intereuropean.it