

Automatic Air Springs building machine

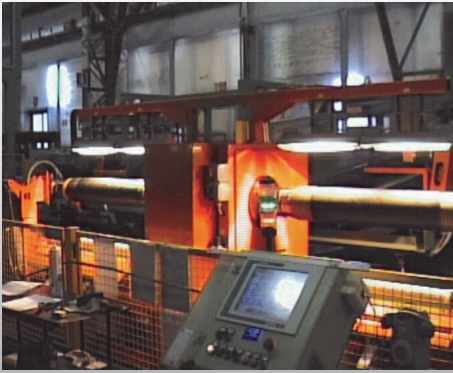

Air Springs Bead set & Turn-up Machine



Air Springs Fatigue Testing Machine



Diapress + BOM Press

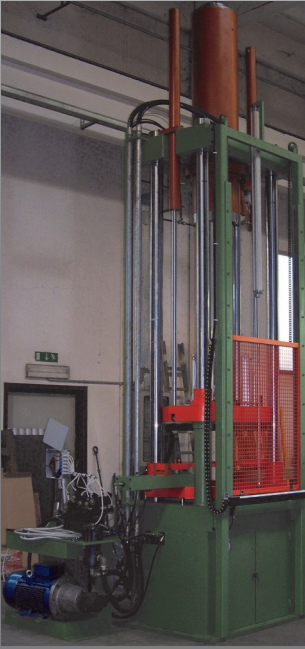

Crimping Press



Air Springs Mounting Machines

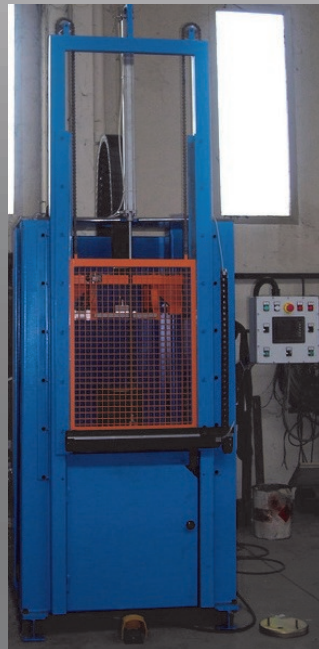

Automatic Air Springs building machines

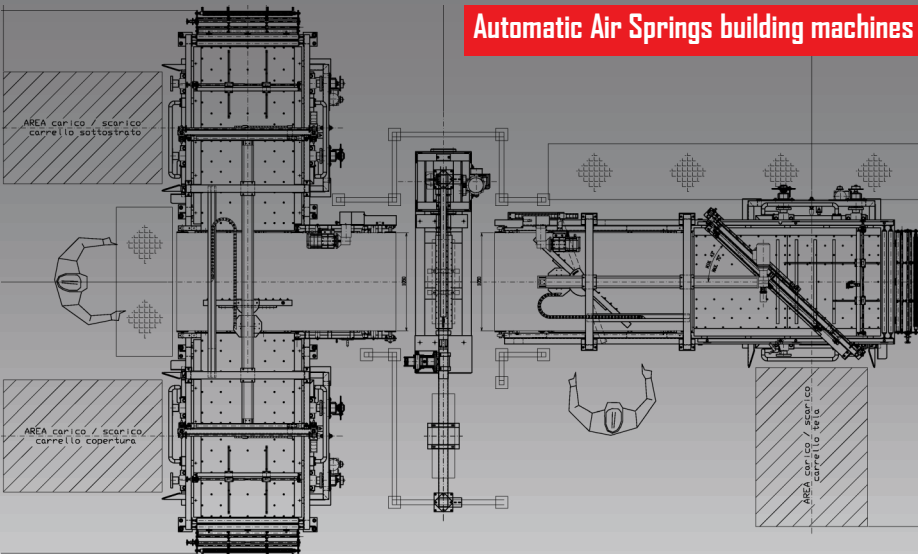

Since 2003...



Tire & Rubber Machinery

Made in Italy

Automatic 1st Stage Tire Building Machines PCR/LT

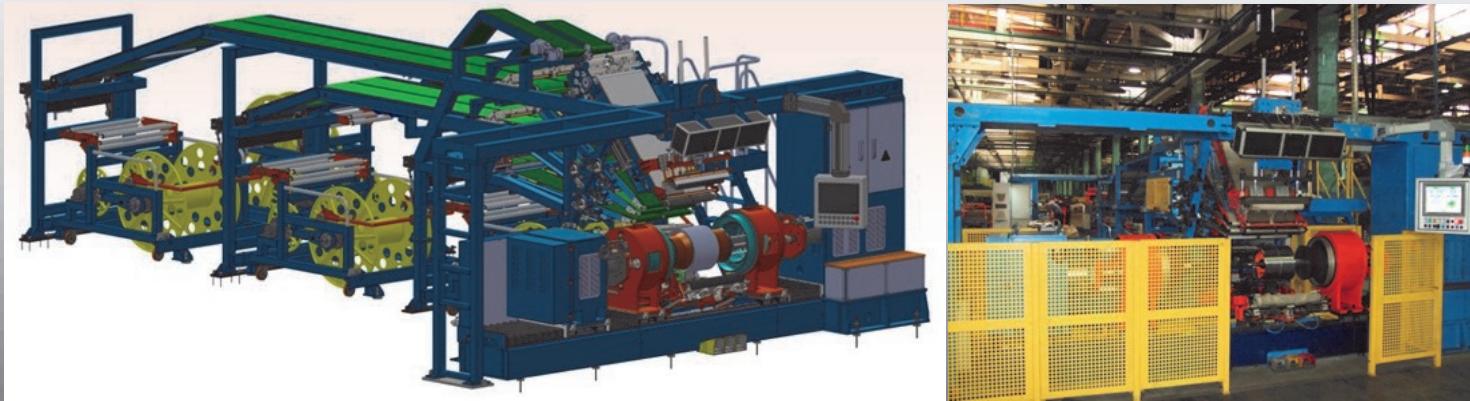

Bead Apexing Line 13" - 20" with tension controlled festoon

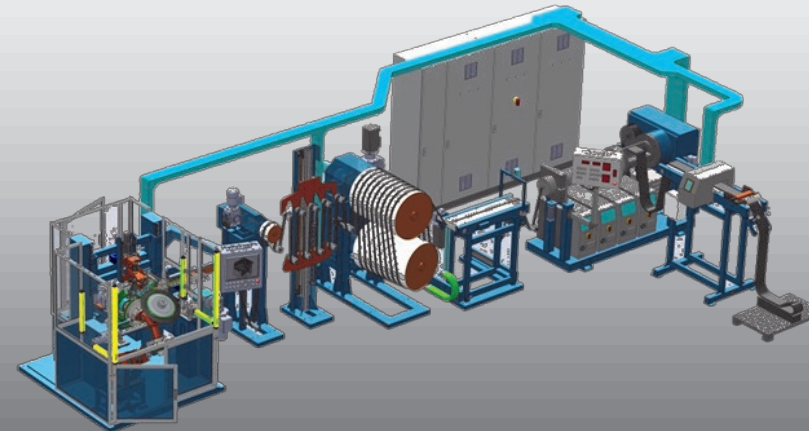

Apex to bead both sides stitching

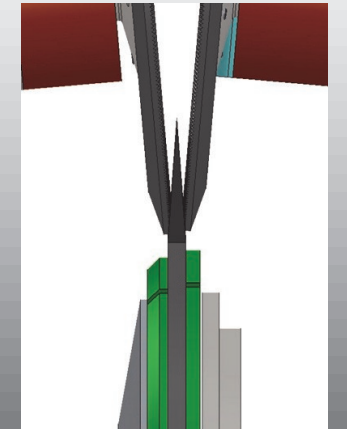

Automatic 2nd Stage Tire Building Machines PCR/LT

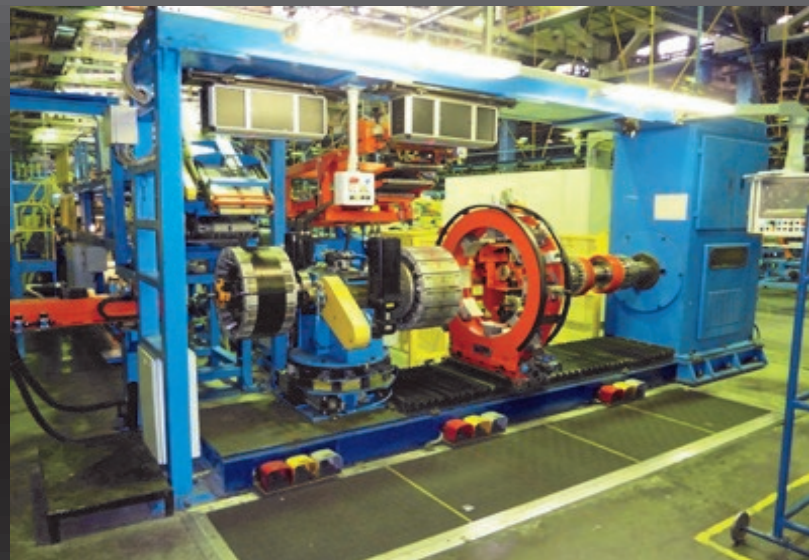

Twin Drums Belt & Tread Turret

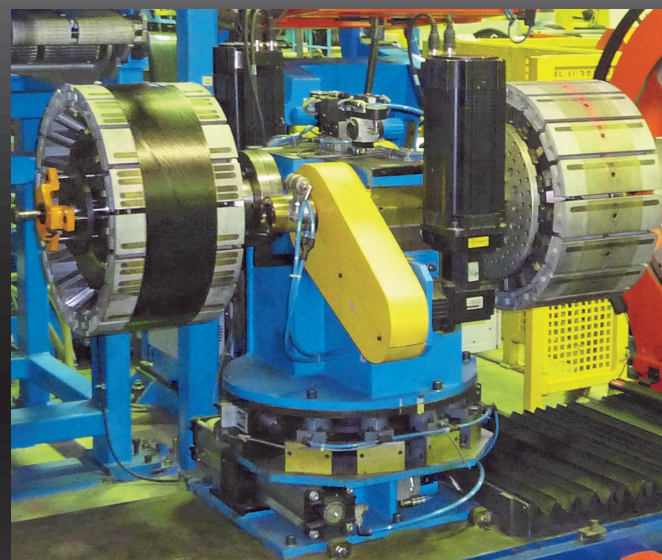

Bead Apexing Line 13" - 20" with cold feed apex extruder



Apex splice quality

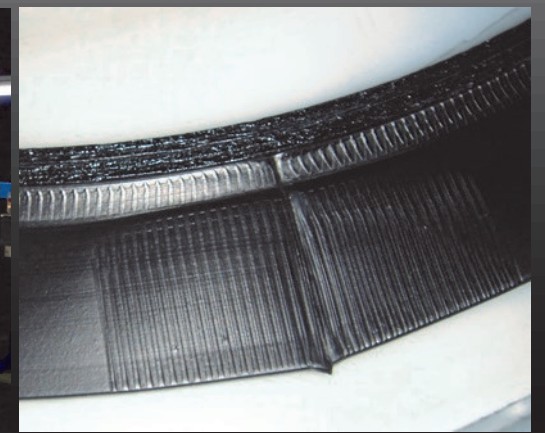

Automatic Dual Wind-up Station



4-Roll Calender

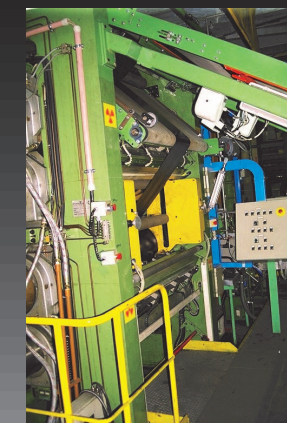

Slitter Lines for Rubber & Textile Strips



Bias Cutters & Strips Winding Lines for Fabric Ply



Fully Automatic Bias Cutter 90°

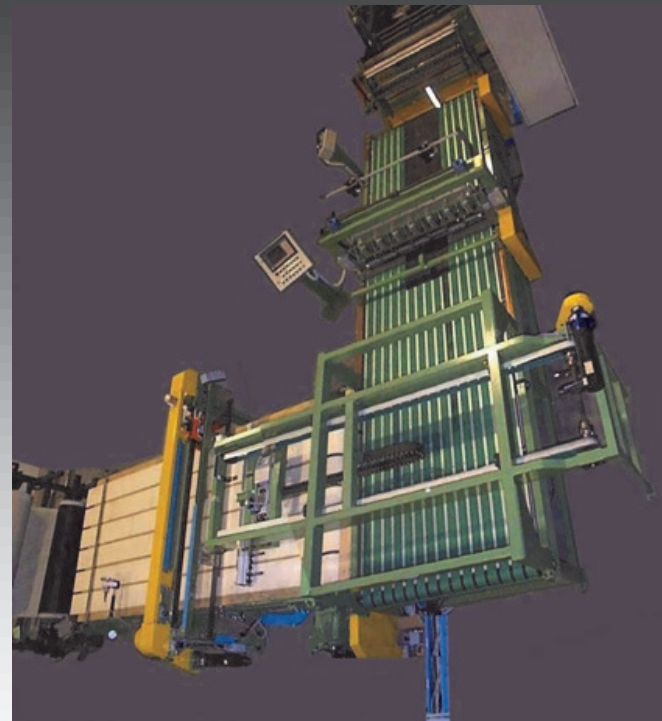

Rubber Calender Line with IL+PLY preassembling

